



Technical Data / Fiche Technique / Technische Daten / Datos Técnicos

Mobile fire point ■ Point feu mobile ■ fahrbare Löschstation ■ Punto de incendio móvil

FireKart









Features/Caractéristiques/Merkmale/Características

For 2 extinguishers including CO₂ (not supplied) • Max combined extinguisher weight: 30 kg • Unit supplied without alarm, fire bucket, etc. • Hooks supplied (KIT109) • Base with drainage slot • Made from non-corroding scratch resistant UV stable PE - 100% recyclable • Optional extras: 10 litres fire bucket (JPFB1); lid (JPBL1), Hand operated aluminium rotary alarm bell, sounds at 60dB for up to 35 m (JRHB); Battery operated electronic alarm with integral strobe for noisy environments, on/off switch with indicator light (JHSA1).

Pour 2 extincteurs (y compris CO₂), non inclus • Poids maximum combiné des extincteurs: 30 kg • Sans alarme, seau incendie, etc. • Crochets fournis (KIT109) • Base avec ouverture de drainage • En PE insensible à corrosion, résistant aux rayures et aux UV - 100% recyclable • En option: Seau incendie de 10 litres (JPFB1); couvercle (JPBL1), Alarme incendie rotative manuelle en aluminium, émettant 60db jusqu'à 35 m (JRHB), Alarme électronique sur batterie avec stroboscope intégré pour environnements bruyants et interrupteur marche/arrêt avec voyant lumineux (JHSA1).

Für zwei Feuerlöscher (inkl. CO₂), nicht im Lieferumfang • Löscheresamtgewicht: 30 kg • Ohne Alarm, Löscheimer, etc. • Haken beigelegt (KIT109) • Sockel mit Abfluss • Aus kratzfestem, korrosionsbeständigem, UV-stabilem PE - 100%ig recycelbar • Extras: 10 l Löscheimer (JPFB1); Deckel (JPBL1); manuelle Alarmglocke, 60 dB bis zu 35 m Reichweite (JRHB); batteriebetriebener Alarm mit Stroboskop-Blitzer für geräuschvolle Umgebung, Ein/Aus Schalter mit Leuchtanzeige (JHSA1).

Para dos extintores, incluyendo CO₂, (extintores no suministrados) • Estable y independiente • Peso máximo combinado de los extintores: 30 kg • Suministrado sin alarma, cubo de incendio, etcetera • Ganchos suministrados (KIT109) • Base con ranura para el drenaje • Fabricado en 100% polietileno que no se oxide, resistente a las rozaduras y los rayos UV - 100% reciclable • Extras opcionales: Cubo de incendio de 10 litros (JPFB1); tapa (JPBL1); Alarma de incendio rotativa operado a mano en aluminio con el sonido a 60 db hasta 35 m (JRHB); Alarma electrónica de batería con estroboscopio interno para sitios ruidosos, interruptor con luz luminosa (JHSA1).

	 mm	 mm	 mm	 kg	 Ø mm	
WEX01-CORE	1300	500	465	11	200 max	Red, Rouge, Rot, Rojo



FM12422

Jonesco (Preston) Ltd.
Pittman Way
Fulwood
Preston PR2 9ZD
England
Tel: +44 (0) 1772 704488
Fax: +44 (0) 1772 702209

Jonesco S.A.R.L.
SECLIN UNEXPO
1524 Avenue de l'Épinette
59113 Seclin
France
Tel: +33 (0) 3 20 32 1111
Fax: +33 (0) 3 20 90 6210
SARL au capital de 8,000 euros



www.jonesco-plastics.com



Technical Data / Fiche Technique / Technische Daten / Datos Técnicos

Mobile fire point ■ Point feu mobile ■ fahrbare Löschstation ■ Punto de incendio móvil

FireKart

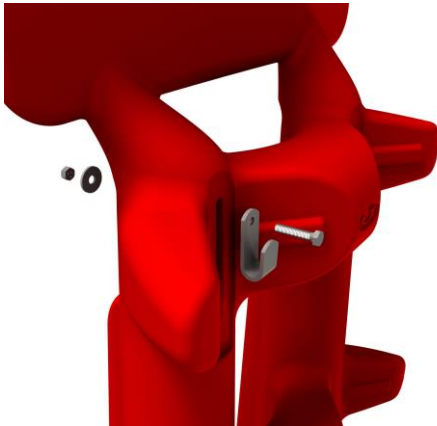

KIT109

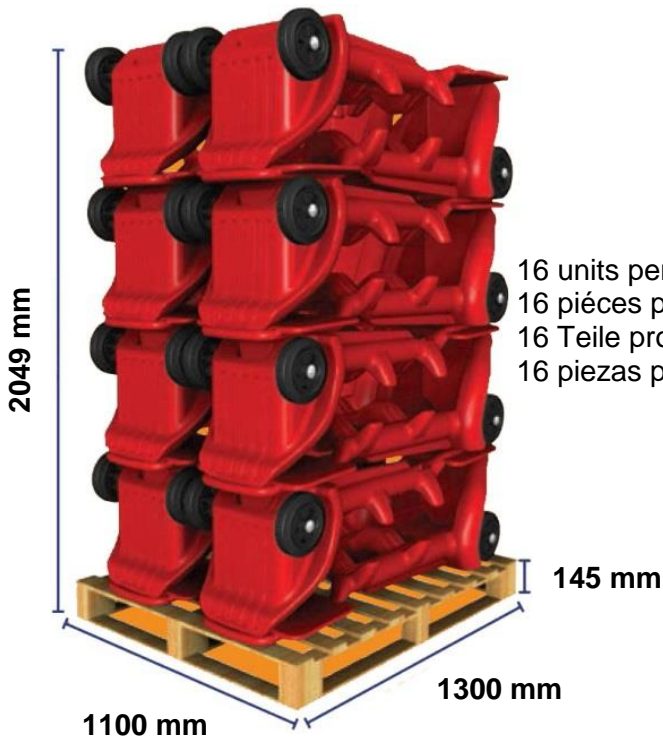
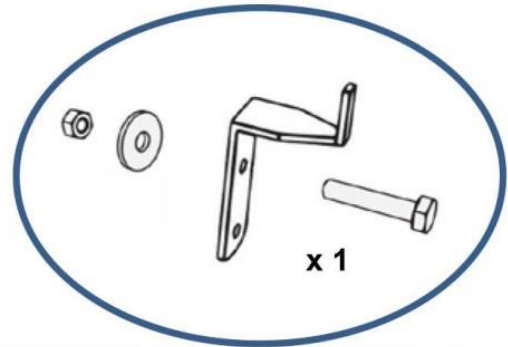
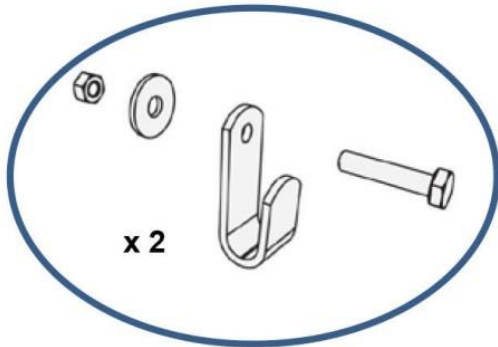

16 units per pallet
 16 pièces par palette
 16 Teile pro Palette
 16 piezas por palé



*not included / non inclus / nicht im Lieferumfang / no incluido



FM12422

Jonesco (Preston) Ltd.
 Pittman Way
 Fulwood
 Preston PR2 9ZD
 England
 Tel: +44 (0) 1772 704488
 Fax: +44 (0) 1772 702209

Jonesco S.A.R.L.
 SECLIN UNEXPO
 1524 Avenue de l'Épinette
 59113 Seclin
 France
 Tel: +33 (0) 3 20 32 1111
 Fax: +33 (0) 3 20 90 6210
 SARL au capital de 8,000 euros



www.jonesco-plastics.com