

Model	Dwg no.	Date	Check	Rev.	Page
KS2A	940604	04/03/2016	AC	0	1/1

**CO2 FIRE EXTINGUISHER 2KG**  
**Certified PED 2014/68/UE and EN 3.7**  
**Fire rating 34B**

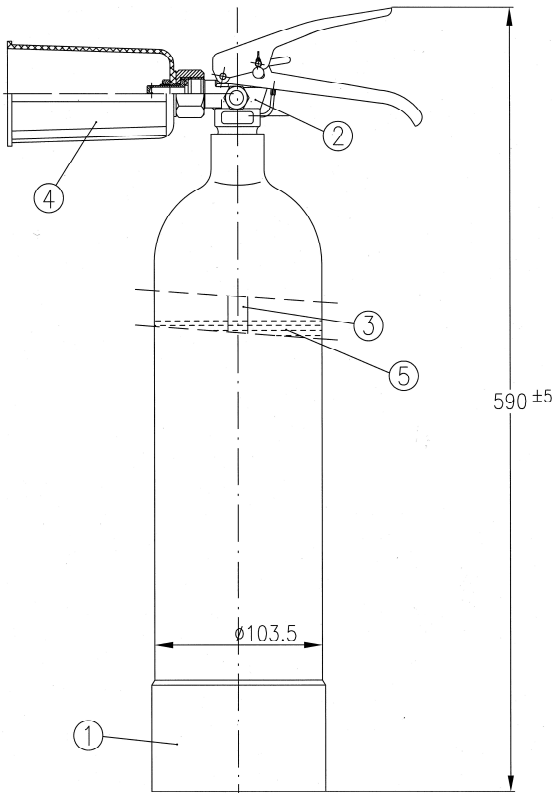

Flammable liquids,  
gasoline, oil, etc

**Technical specification**

- Diameter cylinder \_\_\_\_\_ : 103 mm
- Material \_\_\_\_\_ : Steel cylinder
- Operating pressure \_\_\_\_\_ : ~ 60 bar at 20°C
- Working pressure (cylinder) \_\_\_\_\_ : 174 bar
- Test pressure (cylinder) \_\_\_\_\_ : 250 bar
- Burst pressure (cylinder) \_\_\_\_\_ : ~ 400 bar
- Safety valve \_\_\_\_\_ : 195 bar ~ 230 bar
- Temperature range \_\_\_\_\_ : -30°C + 60°C
- Extinguishing agent \_\_\_\_\_ : CO2
- Nominal charge \_\_\_\_\_ : 2 kg
- Jet length \_\_\_\_\_ : ~ 3 m



**SPARE PARTS**

Pos.	Description	Code
1	Cylinder .....	:0010110
2	Valve .....	: 7204022
3	Dip tube .....	:2230099
4	Hose with snow-horn .....	:2290004
5	CO <sub>2</sub> .....	:2022100

The use of non original spare parts may cause malfunctions loss

**Maintenance and Guarantee**

Maintenance must be made periodically by, trained and certified staff, according to the local regulations of the country where it is located. The extinguisher is guaranteed for 24 months from the date of the supply. The guarantee includes, repairing or replacement for production defects, unit must be sent back to the factory free of charge, only when authorized written agreement with our sales office has been reached. The guarantee expires in case of tampering and bad maintenance made by not-authorized staff.

It must be recharged only by staff authorized and certified by only original extinguisher agent and spare parts.

Technical data are subject to modification for improvements without prior notice